

Successful (and busy) times

The past year and a half have been very successful and therefore very busy for WL | Delft Hydraulics as a whole, and the Industrial Flow Technology department in particular.

The set trend of more experiments, besides numerical calculations, continues. Many test facilities have been used intensively.

New dedicated experimental set-ups have been developed to test special flow phenomena in pipe systems. Examples are air-water-sediment flow in a slowly ascending (transparent) pipe, transport of air pockets in descending pipes, air entrainment in a pump sump due to free falling water from a pipe, and the development of acoustic methods to determine location and volume of air pockets in pipe systems.

In 2007 the IFT department will invest in a new multi-functional loop for the testing of single, two and three phase flow-phenomena. The test loop will have a considerable pipe length to study the different interactions of water, air and sediment in pipeline components and pipelines.



Testrig used for air-water-sediment flow

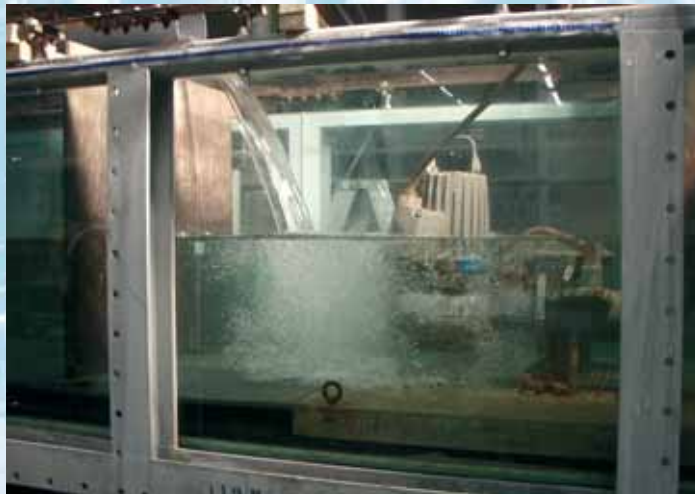

Perspex pump model

Air entrainment in pump sump

Wanda 3.6: Highlights

WANDA's development is a continuous process. The new 3.6 version, released June this year, includes many new and improved features, functions and components. A number of highlights are discussed below.

Validation document

WANDA is validated software. A recent and concise validation document for users is available on: www.wldelft.nl/soft/wanda. The document will be regularly updated as new updates are announced.

Colour indication for component status

A nice new feature of the WANDA interface is the use of different colours to indicate the status of active components (pump, valve, check valve) during the simulation.

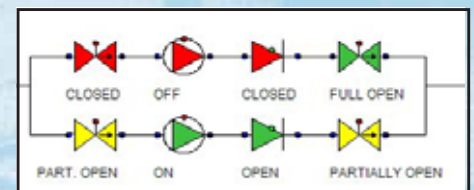

This allows the WANDA to check at a glance whether all active components behave in accordance with the model set-up.

Issue 2007-1
Information on recent developments regarding the pipeline hydrodynamics software package WANDA and the activities of the Industrial Flow Technology (IFT) Group.



New Wanda 3.6 components

Improved diagram readability

Compact and readable schemes can be created with the new 'split H-node' function. A detailed section of the model can be placed in an available open space, while the overall scheme is centred on the page. See an example on page 4.

'Sparse Matrix' integrated

The so-called 'Sparse Matrix' solver has become the standard solver in WANDA 3.6. The solver allows for much shorter calculation times, especially in models containing large nodal sets.

LOG report

Closing a Wanda 3.6 case shows a pop-up screen containing a LOG report, that displays the actual date stamp (together with the former date stamps).

The LOG report can be edited to specify the modifications of the model version, adding to the quality assurance aspect of your project. Use it consistently to minimise the risk of 'forgotten' modifications in versions.

Pump- and system characteristics

A combined chart with several pump- and system characteristics was already available. Now the efficiency and /or power curve for any pumpspeed can be shown in a combined chart

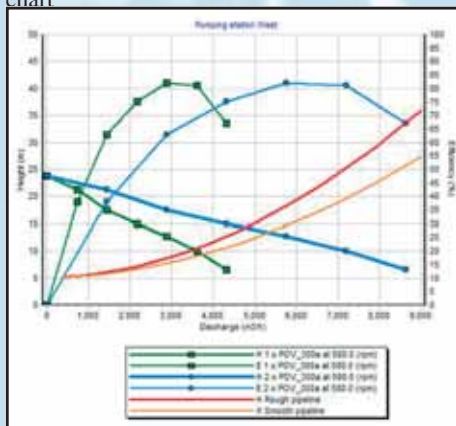

New chart with pump and system characteristics

Case compare tool

This new tool can be used to quickly check the input differences between two cases; a feature that strengthens the quality assurance aspect of modelling with WANDA. Differences in the diagrams are highlighted by shadowing; differences in component properties by colour. You can select the differences for further modifications and/or corrections.

Other improvements

- New output property 'Volume', for all components except Pipe.
- Additional time series for efficiency, power and energy consumption.

The new WANDA 3.6 version includes no less than six new hydraulic components and two new control components. Let's introduce a few of them.

Orifice (specific resist)

For the calculation of an orifice according to Iso 51670-2; 2003.

The initial input value is the hole diameter or the flow rate. In case the output does not comply to the standard, WANDA will warn the user.

Sprays (specific resist)

For fire fighting systems spray installations are applied.

The spray component simulates the specific lay out of a fire fighting system. The number of sprays in use, the status (open/closed) and an action table can be specified to calculate the dynamic behaviour of the system. The initial setting can be either the resistant factor or the flow rate.

V-notch weir

The V-notch weir is used in several applications as a discharge control or level control structure. With this component the edge of a sedimentation tank can be modelled.

Collector channel and Short channel

Both of these open channel components were developed for specific properties of structures used in sewage water treatment plants. The short open channel is a channel with constant bottom slope. The collector channel features distributed lateral inflow. Typical application is the collector channel downstream of a sedimentation tank in a sewage water treatment plant.



New components can be used for engineering of water treatment plants

Flap valve

Pumping stations in polders often feature discharge conduits. Large flap valves are used to prevent return flow in these conduits. In order to simulate the dynamic behaviour of these large valves the WANDA team has developed a special component. This component accurately determines the valve movement based on a 3 dimensional theoretical model of the flap valve. It is now possible to assess the dynamic behaviour of the valve in the design stage.

Epanet Pipe

In combination with the (optional) import function of Epanet schemes, a special Epanet pipe has been developed, supporting different pipe friction models such as Darcy-Weisbach (the standard friction model within WANDA), Hazen-Williams, Manning and Chezy.

Control components

Different dedicated control components have been developed for several clients. The functionality can often be achieved by combining existing control components, but in cases with many controlled pumps in the model, combining all relevant parameters in one component is very useful. The WEC (WANDA External Communication)-component has been developed and used in several interesting applications; for instance to commission PLC's of pumping stations. The WEC component allows communication with for instance Matlab, SCADA-systems, PLC's etc. A brochure with more details will be available on short term.



Commissioning of pumpcontroller using WANDA and WEC-component

Bluewater's FPSO uses WANDA calculations for efficient and safe operations

In the coming months, Bluewater Energy Services will convert its Aframax size ship 'Aoka Mizu' to allow it to fulfill its new FSPO (Floating Production Storage Offloading) role. Bluewater used the WANDA software to simulate marine systems on board and perform essential calculations, before starting the final constructing stage of the FSPO. Pieter Brussen M.Sc. explains.

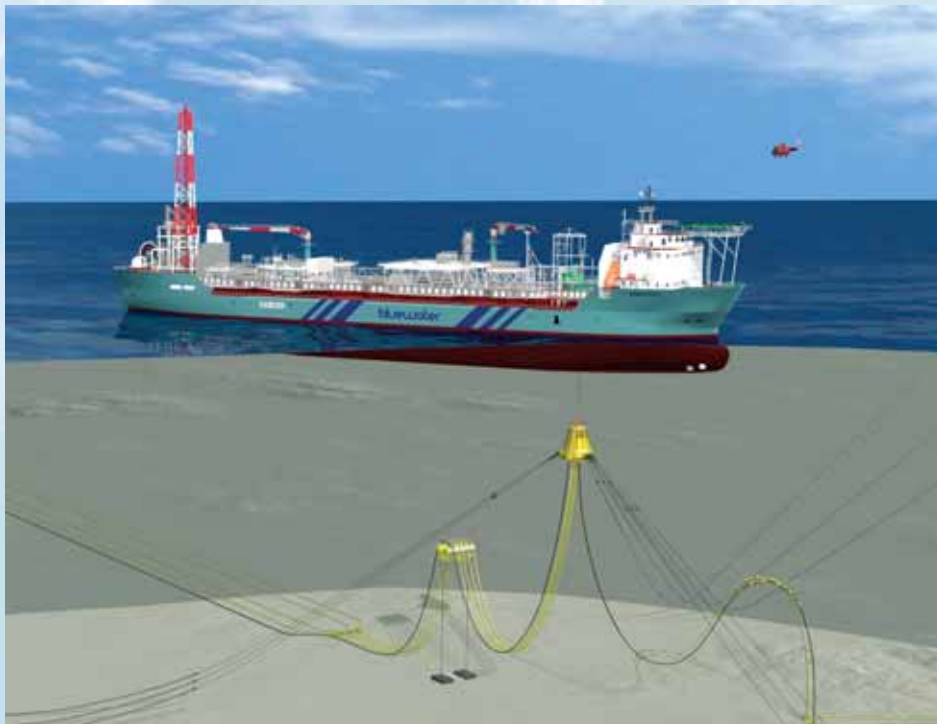

Artist impression of the Aoka Mizu – FPSO

Courtesy of Bluewater, Hoofddorp, The Netherlands

Floating oil rig, refinery and storage tank

“The ‘floating oil rig, refinery and storage’ can explore oil fields in deeper waters, process crude oil and store it on the ship until offloading to tankers. The FPSO shall sail under its own power and shall be able to dynamically position during hook-up to a pre-installed disconnectable buoy with attached mooring and riser system.

We have used WANDA mainly to design and calculate two major systems on board: the cooling system and the cargo-offloading system. The software has helped us to simulate critical situations. Wanda helps organise the system in an efficient way. You are building in a virtual reality.”

Steady-state calculations for the cooling system

“The main function of the vessel closed cooling system is to provide treated and cooled fresh water to numerous consumers. The water is cooled via two off plate heat exchangers. The cooling water is circulated through the system using two circulation pumps.

In WANDA we've build a steady-state model consisting of pumps, valves, pipelines, heat-exchangers and orifices. After entering the equipment height in the system, the model calculated the right hole size for the restriction orifices. These orifices were installed in the pipeline (by the yard) to guarantee the flow of the right amount of cooling water to every single piece of equipment on board. The new component Orifice saved us a lot of engineering work.

The complete hydraulic model yields all the system variables like pressures, pressure losses and flow-rates, and provides insight in problem areas. For instance, in some parts of the system, pressures were too high. By simulating the opening of the back-up loops, a lower cooling water temperature could be applied. To double check the pumps running in a stable working point, several operational modes were simulated, by closing and opening valves. This way the system could be optimised in safety and efficiency.”

Transient calculations for the cargo offloading system

“For the cargo offloading system we have used WANDA to predict pressure surges in the cargo handling piping. It is important to simulate the circumstances surrounding sudden valve closures or pump trips, in order to be able to guarantee safe operation. The calculations were mainly initiated to get advice on the closure time settings of the Emergency Shut-Down (ESD) valve, but other issues concerning the cargo handling system could also be analysed. Simulations were carried out with a tripping cargo pump and without a pump-trip (in case of pump-trip failure).

The results showed that a closure time of the ESD-valve of 10 seconds, without a tripping cargo pump, exceeded the allowable piping pressure rise, proving the need for a longer valve closure time.

The simulated cargo system has also enabled Bluewater to investigate the effect on piping and pumps, in the case of offloading stabilised crude with different properties. This was done for future design issues. Examples are the effect of an increasing density on the liquid-hammer and the shift in operating point of the pumps.”



Courtesy of Bluewater, Hoofddorp, The Netherlands

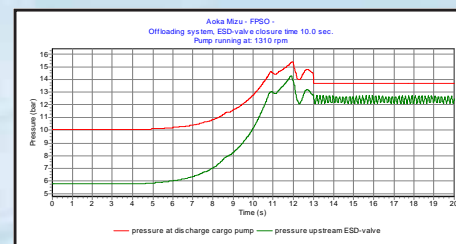

The vertical mounted cargo offloading pump and a graph showing the results of the pressure surge analysis on the discharge side of the pump.

Gas module development progressing

The development of the Wanda Gas module is progressing. A major modification concerns the pipe architecture, a step that has been completed recently. The future pipe architecture will give users a very flexible way of linking different physical properties to the pipe component. It will offer a powerful dynamic simulation of for instance variable temperature, density and compressibility (gas applications). We will keep you posted!



Training on pipeline hydraulics

(Dutch and English)

Every year WL | Delft Hydraulics organises a serie of courses and workshops on pipeline hydraulics, waterhammer, pumps and valves. In 2007 courses were given on waterhammer (2 times) and valves, in Dutch. In addition to these, WL | Delft Hydraulics will organise dedicated short courses or workshops in Dutch or English, in close co-operation with individual clients. Examples include efficient WANDA use, air vessel design, air valve behaviour or a dedicated subset of the standard courses. Please contact Wanda.support@wldelft.nl for more information.



WANDA user conference

The next WANDA user conference (dutch speaking) will be held on February 28th, 2008. Note this date already in your agenda. Beginning 2008 we will send you an invitation



Some impressions of the waterhammer course and user conference 2006

Improving scheme readability

You may improve the readability of your diagram by splitting a H-node

- Step 1: Select a H-node
- Step 2: Choose from the menu : Format - Line&Borders

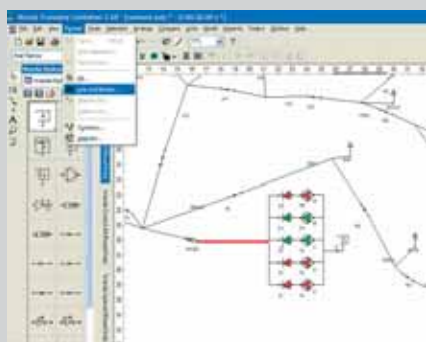

Step 3: select tab Arrows & CrossOvers



Step 4: Mark checkbox Connectors

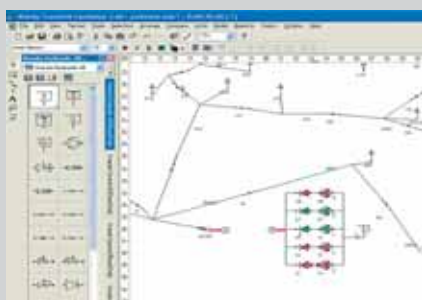

Part of scheme can be moved to any position; connectivity will be maintained

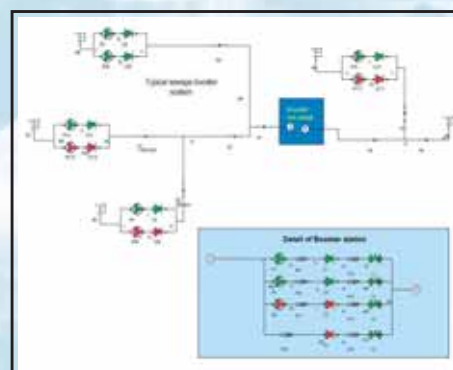
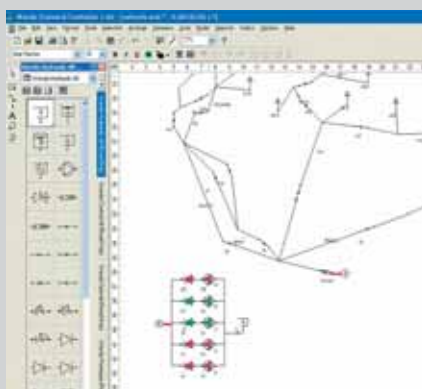

Detailed scheme created with "H-node split"

WL | Delft Hydraulics

Decisive advice: from multidisciplinary policy studies to design and technical assistance on all water-related issues.

Rotterdamseweg 185
 p.o. box 177
 2600 MH Delft
 The Netherlands
 telephone +31 15 285 85 85
 telefax +31 15 285 85 82
 e-mail wanda.support@wldelft.nl
 internet www.wldelft.nl