

## **Deltares, a new institute and an extended field of operation**

The past year has been on of changes. The biggest change was the merger of WL | Delft Hydraulics with Geodelft, parts of the Dutch Ministry of Public Works and one unit of TNO into Deltares. This has resulted in a large institute specialized in Delta Technology with a work force of 850 employees. The focus of Deltares research and specialised consultancy projects is to enable a safe living environment in deltas.

For the unit Industrial Flow Technology it has resulted in a broadening of our scope of work with recirculation studies and a new name: Industrial Hydrodynamics (IHY). Furthermore, a brand new multiphase flow test facility is under construction.

### **WANDA 3.70 released**

Just at the end of 2008, WANDA 3.70 has been released. The main improvement is the release of 15 new components and the improvement of several existing components. Besides the usual bug fixings (very limited for the 3.70 version, proving the high quality of the software), WANDA 3.70 uses Flowcharter 2007.

### **WANDA wiki**

Since December 2008 the WANDA wiki is on-line. The WANDA Wiki is introduced to improve the support to the WANDA community. On this wiki, all relevant information on WANDA can be found, like releases, patches, manuals, FAQ. To get access to the download area you need a login account. Contact our helpdesk ([wanda.support@deltares.nl](mailto:wanda.support@deltares.nl)) if you have not received this login data before. We appreciate your comments about the contents so that we can improve the quality of our support.



### New components in WANDA 3.70

In WANDA 3.70 five new hydraulic components and ten new control components are introduced. These components were mostly created as specials within a project, but because more users were interested, they are now introduced to WANDA 3.70.

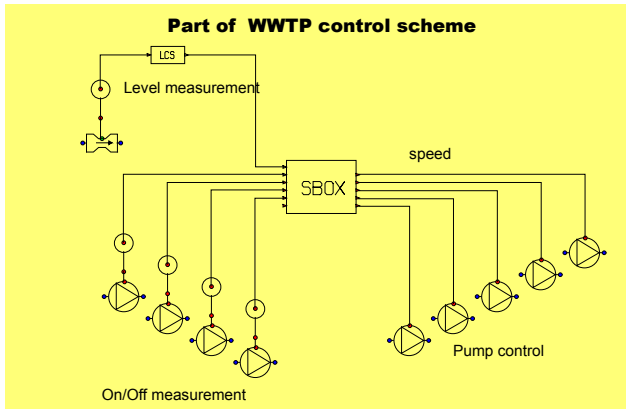

An application in which several new components were used was the shut down protocol of a waste water treatment plant. The hydraulic model of the WWTP consists of channels, collectors and V-shaped weirs. Also for the control system some new components were created. For example a selector was developed to turn on/off a number of Archimedeian screw pumps based upon the number of pumps in operation at the end of the system.

Visit [wanda.deltares.nl](http://wanda.deltares.nl) where you can find a description of all new components. And- of course- when you need a special custom made component, please contact us at [Wanda.support@deltares.nl](mailto:Wanda.support@deltares.nl).

### WANDA 3.71 released

Begin March 2009 WANDA 3.71 has been released. Besides a few minor bug fixes we have improved the error and message handling with respect to the license authorization. Also an estimate is made of the file size of the output file. This size is limited to 2 Gb and a warning will be given if this limit will be exceeded. The main extension of WANDA 3.71 is a new VENT (air valve) type with inflow and outflow characteristics.



In the existing VENT (from now on called "discharge coefficient" type) the capacity must be specified with an inlet/ outlet diameter and discharge coefficients. With this new type the inflow and outflow characteristics available from the manufacturer can be used directly. The great advantage is that with this new type a multi stage outlet air valve can be modelled.



### Cost savings with WANDA by Brabant Water Company

Brabant water is the main drink water supply company of the province of Noord Brabant in The Netherlands. They operate a total of 35 water production facilities in the province of Noord Brabant. To minimize costs Brabant water already optimizes their pump operation for a long period with dedicated software developed by Deltares. It started in 1992 with a program called RenPomp and within new developments in WANDA this functionality was recently also extended in the Pump Energy Module.

One example where Brabant Water has used this module is their water production facility at pumping station Genderen. As input for the model, they used pump data, the system characteristics and the frequency distribution of the flow demand for one year. The easy to use Pump Energy module showed them how to run their pumps in such a way that the energy consumption was minimized. This resulted in a total cost saving of € 8.000 to € 10.000 per year for this pump station alone! For more information how cost savings within pump stations can be realised by using WANDA, please contact us at [wanda.info@deltares.nl](mailto:wanda.info@deltares.nl).





### WANDA goes down under with GHD Consultants

GHD is an international operating consultant, using WANDA since 2006. GHD has chosen WANDA mainly for its ability to model operational control of pumps and valves in water systems, but also for its user-friendly graphical interface and the integration of new research and developments into WANDA over time. Since GHD has started using WANDA, it has been successfully applied in several projects. For example, the robustness of the Perth's metropolitan water supply control system was investigated. The simulations showed that with the appropriate control settings the system was robust enough to withstand pump trip. This project titled "Integrating Perth's Water Supplies" has been awarded with an Engineers Australia Engineering Excellence Award in 2007. Another project is the water hammer analysis for an innovative CETO Wave Power Demonstration Plant. For this study, the positive displacement pump component has been developed by Deltares, which is included in the WANDA 3.70 release.

GHD is very satisfied with WANDA's hydraulic modelling capabilities as well as the open communication with Deltares. For the whole story, please visit the WANDA wiki documentation area / general information at <http://wanda.deltares.nl>.

### WANDA 4 development

The development of WANDA 4 is fully underway. The major difference is the ability to calculate stationary and transient modes of gas transport, multi liquids

(density, temperature, viscosity) and multi phase systems. Examples are: district heating systems, power plants, batch transport through oil pipelines, underground salt mining processes, choke valve break out studies of gas wells, fluid/gas transport, filling of pipelines and many more. To enable these functionalities the architecture of WANDA 4 is currently changed into a new modular design. The user interface will be the same, but the calculation core will be adapted to include thermodynamic calculations, as well as variation of many physical parameters during transport of the fluid or gas through the pipeline. Connected to this core are the different calculation modules, with the required equations to be solved. These modules can be used individually and ordered, resulting in a custom made WANDA version for all users. Of course new components, which make full use

### Example of Tee and Cross components for detailed energy loss calculation

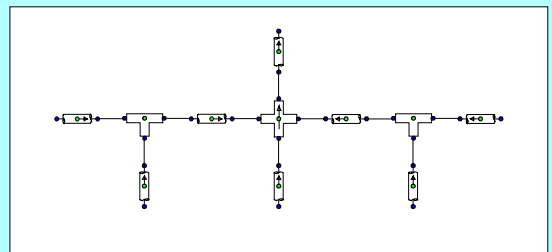

of the new possibilities, will also be developed. Two of the new components which will be included in WANDA 4 are the T and X junctions.

More information is available in the handouts of the WANDA User Conference 2008.

### Dutch WANDA User Conference 2008

On 17 November 2008 the yearly WANDA users day was held in the offices of Deltares in Delft. During this day presentations have been given on the development of WANDA and example projects were shown. There was also room for questions and to express wishes for new developments. As always it was a very informative day. All presentations can be found on the WANDA wiki at <http://wanda.deltares.nl>.

### Architecture WANDA 4

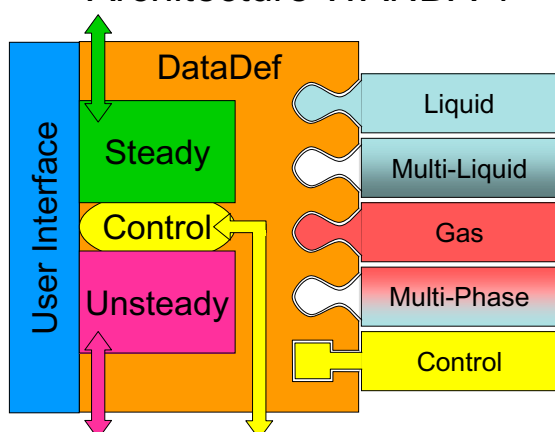

## Courses and workshops 2009

Every year Deltares organizes a series of courses and workshops on pipeline hydraulics, water hammer, pumps and valves.

The dates for 2009 are:

**1-3 April: Water hammer (Dutch)**

**2-3 June: Introduction course on pressure transient (English)**

**4-5 June: Advanced course on pressure transients (English)**

**September: Valves (Dutch)**

In addition to these Deltares can organize dedicated short courses or workshops in Dutch or English, in close co-operation for individual clients.

For more information, please contact [Wanda.support@deltares.nl](mailto:Wanda.support@deltares.nl).



*Deltares is the  
Dutch institute  
for national and  
international water and  
subsurface issues*

# Deltares

[info@deltares.nl](mailto:info@deltares.nl)  
[www.deltares.nl](http://www.deltares.nl)

### Background of the participating institutes

**WL | Delft Hydraulics** was actively involved with water-related issues worldwide, whilst

**GeoDelft** focused on issues in the field of geo-engineering.

**The Subsurface and Groundwater unit of TNO** was active in groundwater management, subsurface/soil remediation and the management and use of the subsurface domain.

**The Department of Transport, Public Works and Water Management (Rijkswaterstaat)** is engaged in providing flood protection and safeguarding adequate supplies of clean water for all users. Rijkswaterstaat has transferred knowledge development for delta issues to Deltares.